

LW-1"

Universal Mast Mounting Clamp for Antennas Based on Mounting on 1" Threaded Tube

DESCRIPTION

- Using the LW-1" universal mast mounting clamp all antennas specifically designed for mounting on 1" water pipe can be mounted on any kind of horizontal or vertical supporting mast tube, as long as the outer diameter of the tube is within 16 to 54 mm.
- Inside the marine sector the 1" water pipe mounting system for antennas has gained worldwide acceptance. The antennas are equipped with a revolving nut, which fits 1" RG (G1" - 11) threaded water pipe. From the Procom line of marine antennas the following models, which are designed for this type of fixation, can be mentioned: CXL 3-1, CXL 2-1/... , CXL 2-3, CXL-VHF/GSM, MARCELL, MARCELL 3+, CXL 70-1/..., CXL 70-3/..., CXL 900-1/..., CXL 900-3/..., CXL 1800-1/..., CXL 1800-3/..., CXL 1800-6/..., CXL 2400-1/..., CXL 2400-3/..., CXL 2400-6/..., CXL 900/1800, CXL 900/1800/1900 and GPS 4/.... These antenna types are immediately installable using the LW-1".
- The LW-1" is a lightweight, epoxy-coated mounting clamp made of non-corrosive aluminium. The accompanying U-bolts and fittings are made of stainless steel.
- The construction of the clamp makes it possible to run the download cable either along the inside or on the outside of the mast tube.
- Please note that an antenna should always be mounted as high and as unobstructed as possible. Objects in the vicinity of the antenna, especially parallel metallic parts (other antennas, wires etc.) may have considerable degrading influence on the SWR and the radiation pattern of the antenna.
- The LW-1" mounting clamp is a member of a complete family of different mounting clamps for 1"-pipe-mount antennas. Below the complete programme is shown. Using the LW-1" or one of these accessory items, a vast majority of all installations can be undertaken.

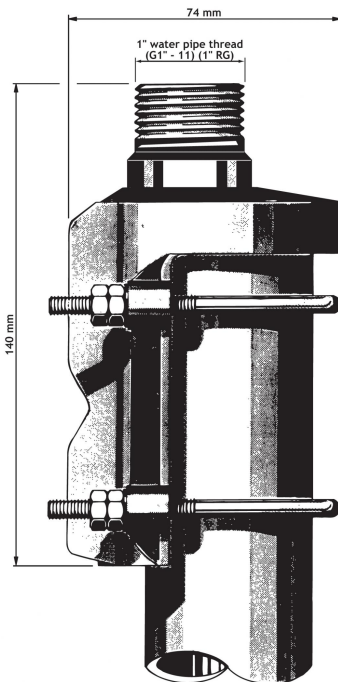

SPECIFICATIONS

MODEL	LW-1"
APPLICATION	Universal clamp for mounting antennas for 1" water pipe fixation on other kinds of vertical or horizontal mast tubes
COLOUR	Gold
DIMENSIONS	See drawing
WEIGHT	Approx. 0.39 kg
MOUNTING	On 16-54 mm dia. mast tube, see drawing

INSTALLATION DETAILS

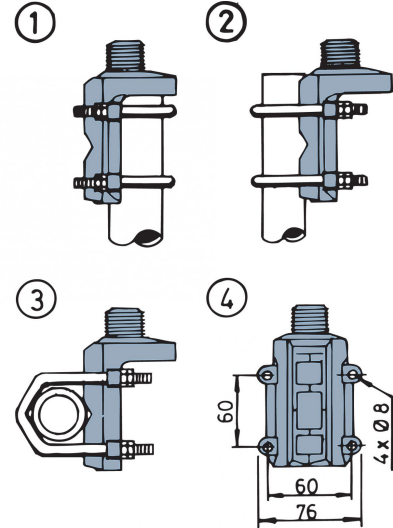

- ① Mast tube D_i , min. = 30 mm
Mast tube D_o , max = 54 mm
- ② Mast tube D_o , max = 54 mm
Mast tube D_o , min = 16 mm
- ③ Mast tube D_o , max = 54 mm
Mast tube D_o , min = 16 mm

OTHER ACCESSORIES

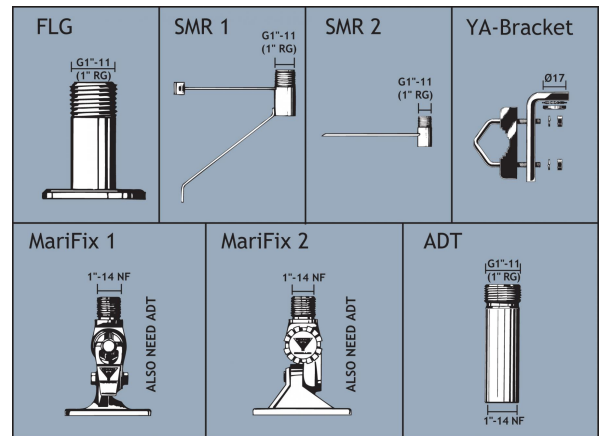

ORDERING DESIGNATIONS

TYPE NO.	PRODUCT NO.
LW-1"	110000037

 PROCOM A/S reserve the right to amend specifications without prior notice.
11/11/11